

ZONE		REV	ECN	DESCRIPTION	DATE	DR	APP
G3	Q	6463		REDRAWN ON CAD, AND (1) MALE ADJUSTING WASHER ITEM 15 WAS REMOVED FROM BETWEEN THE FOUR-POINT CONTACT BALL BEARING ITEM 53 AND THE LOCK WASHER ITEM 99	2/13/96	AMV	PN
R		6678		UPDATED DRAWING SHOWING REVISED SEAL HOUSING SPACER, 7/16/96 DISTANCE SLEEVE, 5340489 WAS 5340040, ITEM# 43, 5340652 WAS 5340069, ITEM# 117, 9910036 WAS 1217 & WAS 1, ADDED ITEM# 146 & 147, AND DELETED 603 AND 604.		AMV	PN

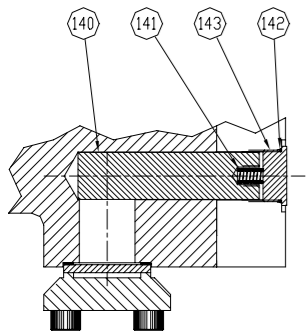

VIEW SHOWING ECONOMIZER PORT PLUGGED

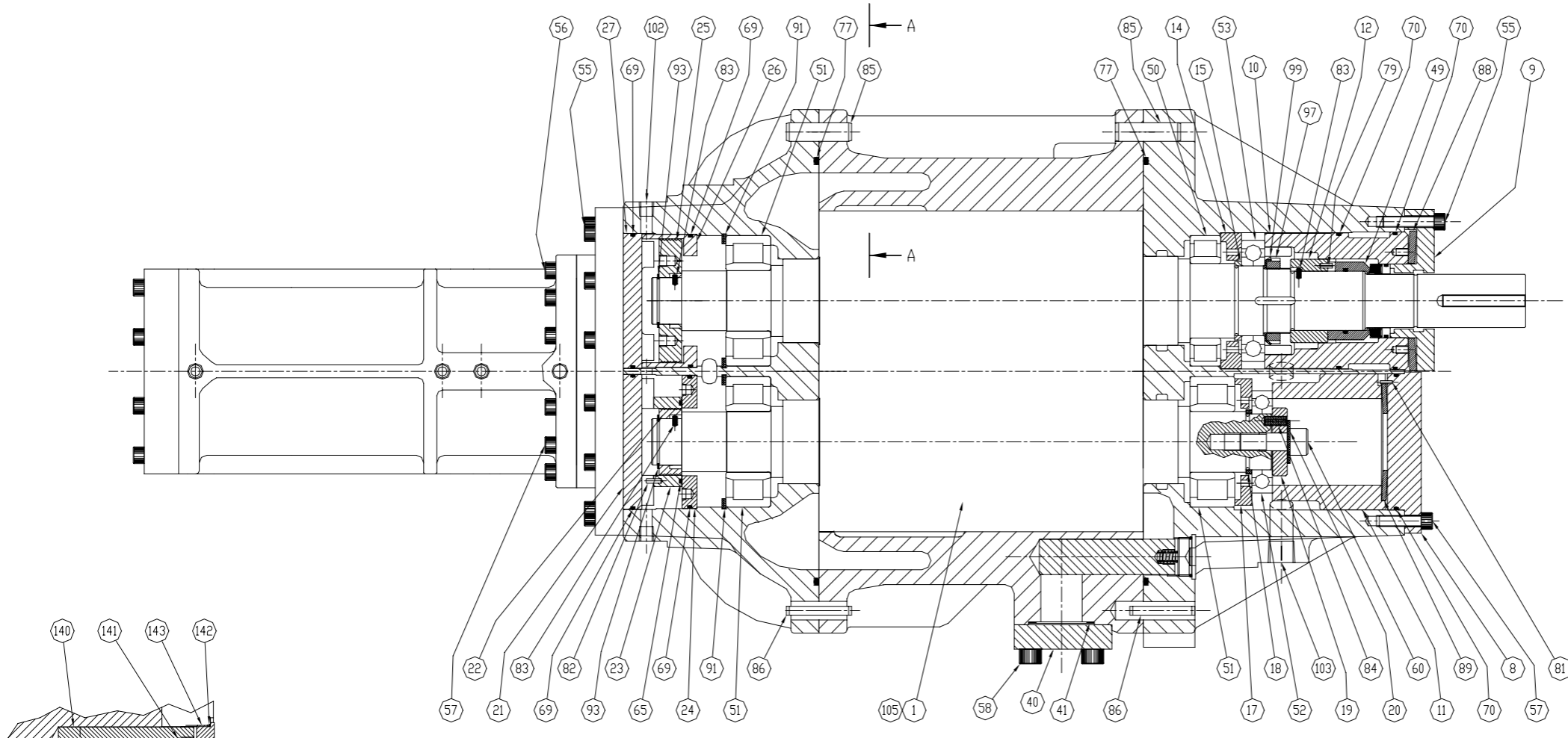
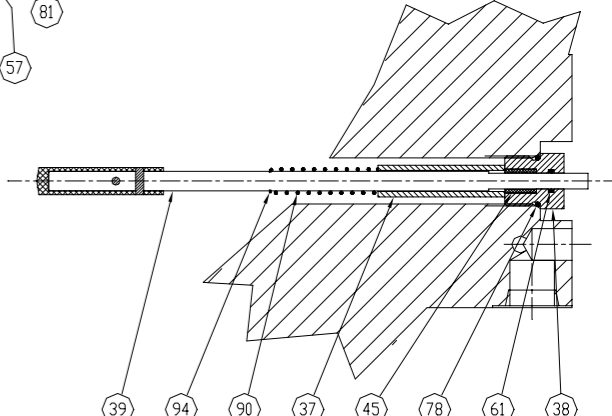

SECTION A-A FULL SCALE

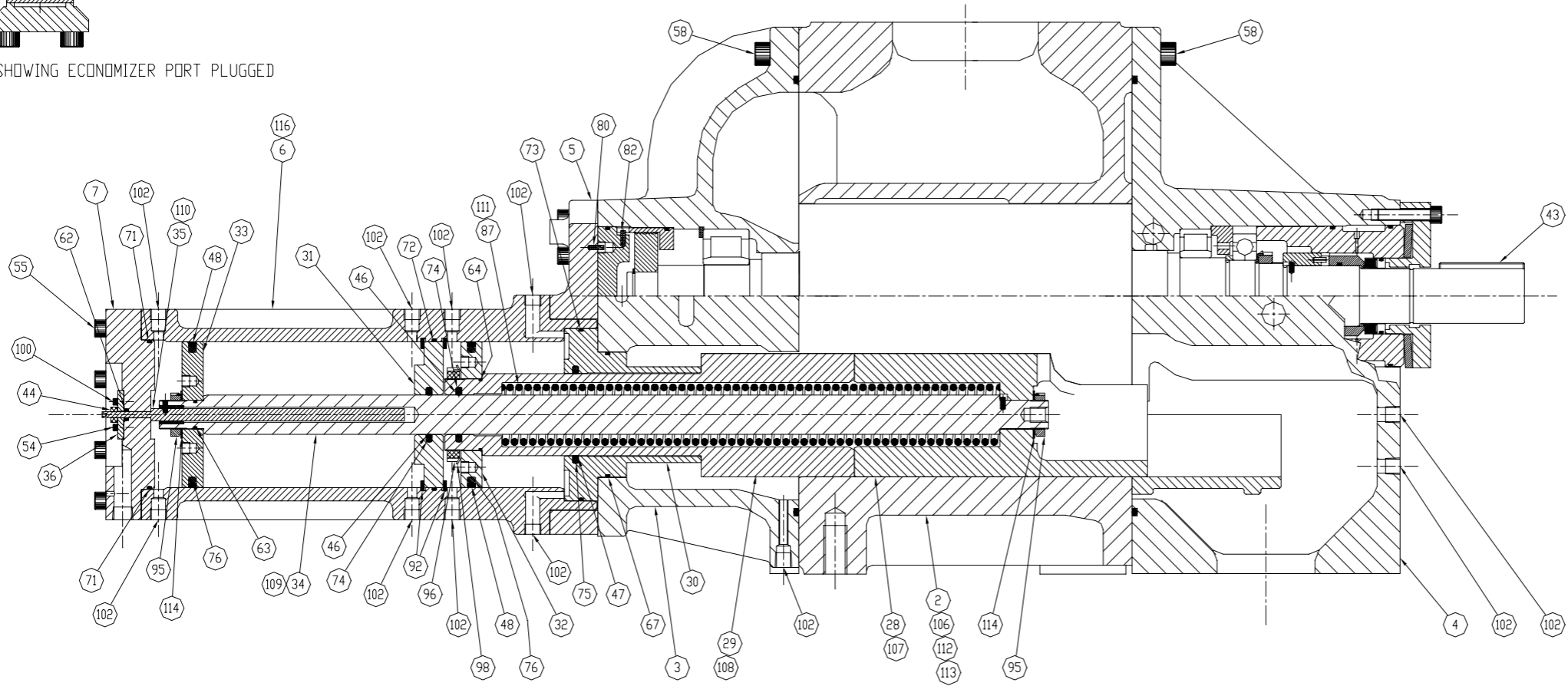

IMPORTANT NOTE FOR INSTALLING SEAL HOUSING SPACER
 WHEN INSTALLING SEAL HOUSING SPACER, ITEM 10, BE SURE THAT $\phi.125$ MATCH MARK IS ALIGNED WITH $\phi.187$ MATCH MARK ON THE DISCHARGE CASING.

Frick YORK INTERNATIONAL		FRICK COMPANY Waynesboro, PA 17268	
SCREW COMPRESSOR D=193 L/D=1.35 & 1.8 CROSS SECTION ASSEMBLY			
DR: ALLAN WEBER	DATE: 2/13/96	CAGE NO:	SIZE:
CHK: ROBERT HECKMAN	DATE: 2/16/96	23587	E
APP: PAUL NEMET	DATE: 2/19/96		
REV	REV	REV	REV
		534E0169	R
SCALE: 1:2	SUPPLIES:	SHEET 1 OF 2	

